



Eclipse Hv100 Brand ID liquor dispensing system User Guide



 **Eclipse Hv Series**

Table of contents

1. General information	3
1.1. Pour sizes	3
1.2. System maintenance	4
1.3. Number of dispensing station	4
1.4. Serial printer	4
1.5. Activator ring	4
2. Installation	5
2.1. Considerations	5
2.2. Power supply	5
2.3. Installing the barcode labels	6
2.4. Installing the pourers	8
2.5. How pourers work	8
3. Programming modes (key to Program)	9
3.1. Testing the pour sizes	12
4. Operation (Key to Run)	12
4.1. Default pour size	12
4.2. Functions	12
4.3. Using the Eclipse	15
4.4. Pour spout operation	16
5. Installing the printer	17
5.1. Printer settings:	17
5.2. Serial printer cable pin out	17
5.3. Multi-system selector switch	17
6. Selecting the serial port	17
6.1. Serial communication cables	18
7. Networking Eclipse systems	19
7.1. Rs-422 Hub	19
7.2. Modular splitters	19
7.3. Using Data/Voice Outlets	19
7.4. Ordering the cables	20
7.5. Rs-422 CABLES	21
7.6. Network schematic	22
8. Interfacing the Eclipse Hv 100	23
8.1. Automatic sales transaction	24
8.2. LDS (liquor dispensing system) suspense file	24
8.3. Flow of data	24
8.4. PLU table	25
8.5. Trouble shooting the interface	26
8.6. Testing the liquor system	26
9. Maintenance	27
9.1. Dispensing liqueurs	27
9.2. Rinsing pourers	27
9.3. Cleaning pourers	28
9.4. Testing pourers	28
9.5. Activator ring maintenance	29

10.	Part list.....	30
11.	Hardware Warranty	31
12.	Annexe: PROGRAMMING AND OPERATING FLOW CHART	32

1. General information

The Eclipse Hv 100 can identify 100 different barcode labels applied to Auper pourers. The barcode on the labels identify the spout numbers from 0 to 99.

The Liquor Manager software must be used to program the Eclipse Hv 100. Four pour sizes can be programmed for each brand. The system automatically reverts to the Regular portion after a few seconds of inactivity.

Every drink poured by the bartender will be registered. The counters can be read from the display, a report can be printed to a serial printer or the Liquor Manager software can be used to read and save the information on your computer disk. The Liquor manager software can communicate with up to 100 Eclipse systems networked to your computer.

The serial printer report will list transactions by bottle number, brand name, pour size used (A, B, C or D), and the individual prices or size and the total value for each. The «\$» field for each pour size can be used to total the amount dispensed in Oz (or ml) or the amount of money that should have been collected. In addition, each report identifies the system number and the report number.

The Eclipse Hv 100 is ready to interface to POS systems and cash registers that have software to interface to liquor systems.

When setting up a liquor system, which is not interfaced, special considerations should be given to the existing cash register reports. A good liquor system setup is one that will provide the bar manager with a liquor usage report which can be easily compared with the cash register report. If the information coming from both systems cannot be easily compared, the managers will have a tough time reconciling sales and usage.

A thorough analysis performed by both the owner/manager of the bar and the dealer is the key to customer satisfaction. This analysis should prevent programming errors which could temporarily disturbed the work of the bartenders and create a negative attitude in the bar area.

1.1. Pour sizes

When setting up the Eclipse, you can program up to 4 portions per pourer number. The portions are selected and calibrated according to the cocktail recipes. Some brands will require all four pour sizes while others may require only one. This analysis should be performed by the bar manager and if possible with the bartenders who will be using it. To set a pour size to zero locks it and bartenders will not be able to use it. The most used portion size for any given brand should be programmed on the R (regular) button. The system goes back to the "R" pour size automatically 5 seconds after the last pour is finished. The pour sizes are set by time intervals. A setting of 40 will pour approximately 1 ounce (30 ml).



1.2. System maintenance

Proper maintenance of both the pourers and the activator ring will maximize the performance of the liquor system. The number of pourers available for each brand should be sufficient to insure that no pourer will be taken off an empty bottle and put back onto another one without being clean thoroughly using the magnetic cleaning device.

Once the system is installed and running, all the employees who will be using the liquor system, or do the daily maintenance, should attend a pre-scheduled training session. During that meeting, it is important to teach the bartenders how to use the Eclipse, explain the available functions, the actual setup and explain in detail the daily maintenance procedures. The system is supplied with a CD-rom containing a video, which should be viewed by every employee using the system.



1.3. Number of dispensing station

One Eclipse Hv 100 per bartender working behind the bar is recommended unless sales volume does not justify it. The number of drinks dispensed per hour should be evaluated to guarantee your bartenders have enough firepower to meet the demand. During peak periods it would be unfortunate to see bartenders having to wait for the liquor system to serve a drink. An interfaced liquor system can increase the speed of service if the POS or register is set up to automatically register drinks as they are dispensed. This factor may have to be considered as well.

1.4. Serial printer

When a serial printer is ordered from Auper Electronic Controls Inc, we supply the Samsung SRP-270 serial printer (part # 70-400). The printer is connected directly to the liquor system using the RS-232-C cable supplied (by Auper) with the printer. This printer is pre-configured at the factory and is ready to print when you receive it.



1.5. Activator ring

Even though, the Eclipse's activator ring is built to be liquid resistant, with age and repeat usage, the seal where the cable enters the ring may deteriorate. **DOT NOT WASH THE ACTIVATOR RING UNDER RUNNING WATER OR SUBMERGE THE RING TO CLEAN IT.**

Use the 1.25 m 9-pin to 9-pin extension to connect the activator ring to the Eclipse. **DO NOT CONNECT THE ACTIVATOR RING DIRECTLY TO THE ECLIPSE.** Secure the connection using the 2 plastic clamps one on each connector.



2. Installation

The Eclipse Hv 100 should be installed close to the liquor bottles in the bar. The system is normally mounted under the counter with the activator ring holder mounted on the right of the liquor system. **Soft drink dispensing guns used to prepare cocktails should be installed on the left side of the liquor system** since most people are right handed. Bartenders typically pour liquor using their right hand and use their left hand to top off the drink with the soft drink dispenser.

2.1. Considerations

- Avoid installing the activator ring above a sink where it can fall in water.
- Secure power supply away from splashing water and above floor level.
- Fill the gap between the Eclipse and the bar with silicone to prevent spilled liquids from finding their way between the Eclipse and the bar.
- The activator ring support must be installed high enough as to have enough clearance between the bar and the bottom of the bottles.



2.2. Power supply

- The Eclipse is powered by a 24 volts @ 40 Va power transformer.
- Check that the electric outlet was intended for electronic equipment before connecting the power supply.
- In some building, the installation of an uninterruptible power supply (UPS) may be necessary if power fluctuations are suspected. The UPS are found in computer supplies stores. The battery back up of the UPS will stabilize the voltage to the Eclipse.



2.3. Installing the barcode labels

The reflective barcode labels for the Eclipse systems are supplied of sheets of 27 labels. There are five sheets in the series:

- Sheet No.1: barcodes 0 to 8 (three of each for No. 0,1, 2, 3, 4, 5, 6, 7, 8)
- Sheet No.2: barcodes 9 to 22 (two of each for No. 9,10,11,12,13,14,15,16,17,18,19,20,21)
- Sheet No.3: barcodes 19 to 45
- Sheet No.4: barcodes 46 to 72
- Sheet No.5: barcodes 73 to 99

These labels are extremely resistant to wear and offer maximum optical performance that will not diminish with age and wear. Since these labels will eventually have to be replaced, either to re-assign a pourer to a different product or because it has been damaged, it is important when a label is removed that the glue remains on the label and not transfer onto the pourer. If it did, the glue would be difficult to remove thus our choice to select glue that is not overly aggressive. The reflective material is extremely rigid making it difficult to apply since it cannot be stretched in position as you could with vinyl labels.

We have developed a method to install the reflective barcode labels on the pourers that should facilitate their installation and extend the life of the labels by preventing corner form curling up.

We strongly recommend cleaning the barcode label sheets with alcohol to remove the greasy film left by the printing process and fingers of the people who have manipulated the label sheets during production and shipping.

Soak a paper towel with rubbing alcohol and wipe the barcode label sheet thoroughly. The alcohol will dry in a few seconds. Remove the barcode label with a utility knife and avoid touching the overlapping ends of the label with your fingers while you apply the label to the pour spout.

This procedure will insure maximum adhesion of the glue over the label.

Barcode label installation

Steps

- Use the point of the knife and your thumb to lift the label off the sheet.
- Take the label with your fingers holding it by the middle. Do not touch the ends with your fingers, as it will put grease on the glue.
- Install the label starting from the middle following the top edge keeping it as straight as possible.
- Slowly push the label to apply it on one side taking care not to trap air bubbles underneath it.
- Complete the other side to make the joint in the same manner.
- If the label is not 100 % straight, the top corner will curl up and not stick well. Use the point of the knife to remove the excess material to obtain a perfect joint. It is not important that the barcodes be 100 % aligned at the joint.
- Allow 24 hours before you soak the pourer in water to give enough time for the glue to stick well.

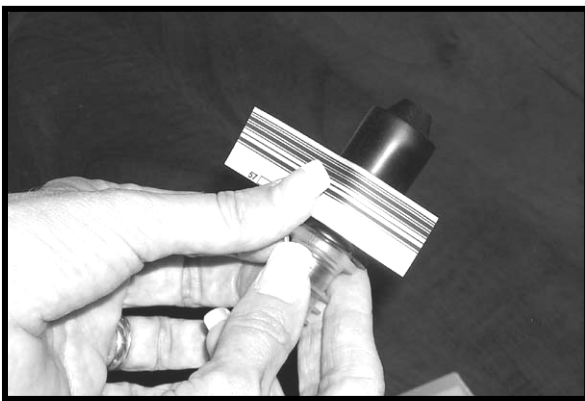
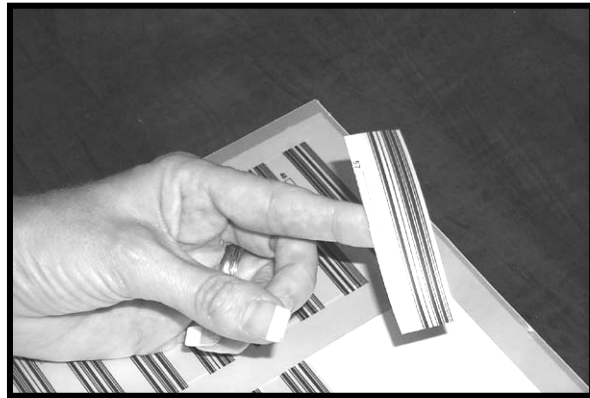
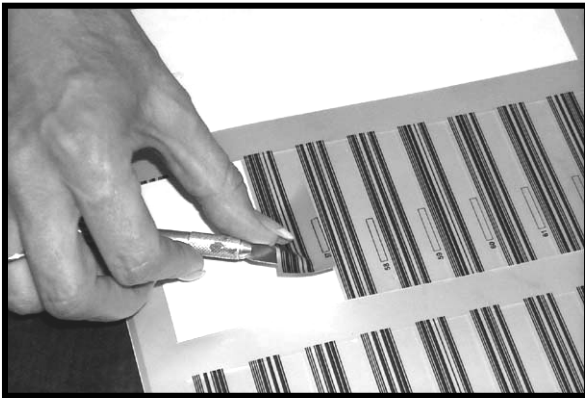

2.4. Installing the pourers

- If a cork is loose it will leak and the liquor will spill in the activator ring.
- If a cork is too tight:
 - You will have a hard time pushing the pourer into the bottle.
 - It may lose its round shape and leak at the base of the pourer.
 - It will be extremely difficult to remove from the empty bottle.
 - 9 times out of 10, the breather tube will end up at the bottom of the empty bottle.
- Use the red cork for larger bottlenecks.
- Trim the top wings of the clear cork to reduce the size for smaller bottlenecks.
- Corks wear out and should be changed when they leak.
- Try using the same pourer for each brand.
- Once the pourer is installed, invert the bottle and check for leaks.



2.5. How pourers work

The principle of operation can be compared to pouring gas using red canisters. If you block the air inlet, the flow of gas will choke and rapidly stop because no air penetrates in the canister.

The air inlet on Auper pourers is located between the base of the pourer and the cork as shown on the picture. The air enters the bottle through this hole and finds its way inside through the breather tube.



The breather tube is equipped with two check valves that prevent liquid from escaping the bottle through the air hole when the pourer is inverted with the valve closed. When the activator ring is energized, it opens the valve in the pourer, which lets the liquid out. As gravity pushes liquid out, air is sucked in through the breather tubes. In order for a pourer to function properly, the breather tube check valves must operate freely and the air inlet must not be blocked. **People using heat shrink seals, must make a small hole between the cork and the base of the pourer to let air in for the pourers to work well.**

3. Programming modes (key to Program)

All of the following functions and features can be programmed and enabled from the Liquor manager software. The following instruction will help you do some of them manually using the key pad. The brand names associated with the barcode numbers and the prices cannot be changed from the keypad. You must use Liquor Manager to program them.

- Turn the key to program

- The display will show:

POUR SIZE TIMER: TIMER 00B 0000

- The pour sizes are set using time intervals between 0 and 255.
- 00B is the barcode number, B identifies the pour size button. (A=S, B=R, C=L, D=SP)
- The last four digits on the right identify the TIMER value.
- A value of 40 equals approximately 30 ml (1 oz) depending on the viscosity of the liquor. If the viscosity increases, the timer settings will have to be increased.
- A TIMER value of 20 will pour 15 ml (1/2 oz).
- A TIMER value of 80 will pour 60 ml (2 oz).

1. Press the S button to change the pour size going up.
2. Press the R button to change the pour size going down.
3. Press the L button to increase the TMR value.
4. Press the SP button to decrease the TMR value.

Tip:

To change a pour size manually for a specific bottle, before turning the key to program, insert the pourer into the activator ring to read it. The bottle number will be identified. Turn the key to program and the display will bring up the TMR value of this specific bottle.

Press M once: the display shows **POS INTERFACE**

- Press SP to change it to POS ENABLED (1), (2) , (3)
- The number between brackets identifies the POS protocol used (see interface section).
- Press L to change the protocol number (the most commonly used is 1)
- When set to POS ENABLED, the Eclipse is in INTERFACE MODE.
- See the interfacing section for details.
- Before you proceed, make sure the system is set to POS DISABLED.

If set to POS INTERFACE: ENABLED, press M once: the display shows **ACK TIMEOUT = 4s**

- Press the R or S button to increase or decrease ACK timeout delay in seconds. (1-9 seconds)

Press M again: the display shows **4-DIGIT PLUs = Y**. If you have shorter PLUs, press SP and display will show **4-DIGIT PLUs = N** and zeros before number will not be added Ex: PLU 21 will be seen as 21 and not 0021.

Press M again: the display shows **BAUD RATE: 2400bps**

- Press L or SP to change to 9600 bps or 19.2Kbs

Press M again: the display shows **DATE: 10/06/00**

- Press the S button to change the month going up.
- Press the R button to change the day going up.
- Press the L button to change the day going down.
- Press the SP button to change the year going up.

Press M again: **TIME 12:00:80**

When setting the clock for the first time, the seconds are set to 80 at the factory to disable the clock to save the battery.

- Press the S button to change the hour going up.
- Press the R button to change the minutes going up.
- Press the L button to change the minutes going down.
- Press the SP button to change the seconds going up or to start the clock.

Press M again: **Nb. OF PERIODS = 1**

The periods can be used to identify different price categories or shifts. For each period a different price can be programmed for each brand and pour size. Each period has its own set of counters.

- Press « L » or « SP » to select the number of periods to be used.
- Up to 3 periods can be saved daily.

Press M again: **PERIOD STARTING: PERIOD #1 01:00**

- Press « S » or « R » to move to next period.
- Press « L » to change the hour.

- Press « SP » to change the minutes.
- The number of periods must have been entered previously.

Press M again: **END OF DAY MODE: EOD ENABLED/DISABLED**

The end of day mode is used to turn the optical sensors OFF automatically at the end of the day at the EOD time set in the machine. The sensors will automatically be turned back ON at the time set for period 1.

- Press the SP button to enable or disable this mode.

Press M again: **END OF DAY: 02:00**

- Available only if the End Of Day in enabled
- Press the L button to change the time
- Press the SP button to change the minutes

Press P again: **PROMOTION MODE: PROMO. DISABLED/ENABLED**

The Promo mode enables the bartender to identify a drink as a complimentary drink prior to serving it. The drinks identified as “promos” will be totaled on a different report.

- Press the SP button to change between DISABLED/ENABLED.

When setting Promo to “enabled” the bartender can press the M button after the bottle has been inserted in the activator ring before serving it.

Press M again: **SYSTEM NUMBER 00**

The system number is used to identify each Eclipse on a network. The system number will also appear on a report sent to a serial printer. The Liquor Manager software uses the system number to identify the Eclipse system it is talking to or receiving information from. Each system must have a different system number. Numbers start at 00 up to 99.

- Press the L button to change the system number going up.
- Press the SP button to change the system number going down.

Press M again: **RET TO DEFAULT SIZE :**

ENABLED

- Press the SP button to select if default pour size should be enabled or disabled on your system. By enabling, the pour size will revert back to pour size programmed. To do so, press on M to choose your default pour size.

- Enter default pour size by pressing on button desired. S (small) R (regular) L (large) or SP (special)

3.1. Testing the pour sizes

- Make sure the system is on the POS DISABLED MODE
- Turn the key to RUN
- Insert a pourer in the activator ring.
- Select a pour size and invert to pour.

4. Operation (Key to Run)

- The first serving mode shows the bottle number, the pour size, the brand name and price on the display.
- The second serving mode shows the date and time, the brand name, the corresponding portion letter (a, b, c ,d) and the price programmed in the machine corresponding to the barcode number instead of the bottle number.
- In either one of these modes, the machine is in serving mode. The Fault light is Off and the pour size buttons are active. To change the serving mode press the M button.

The Eclipse will read and pour liquor in any of the functions of the operating mode. But keep in mind that the pour sizes cannot be changed while in function 3 to 10. Consequently the system should be used to pour only when the system is in function 1 or 2.

4.1. Default pour size

If **RETURN TO DEFAULT POUR SIZE** has been disabled, the last pour size selected will remain until changed by the bartender. If **RETURN TO DEFAULT POUR SIZE** has been enabled, the system will revert back to pour size selected in the programming mode.

4.2. Functions

Press on the M button to go to the next function.

Function	Display	Serving mode
Function 1:	BOTTLE INFORMATION Displays the bottle number, pour size selected, brand name and price	YES

Function 2: **DATE / TIME** **YES**
Displays the date and time, brand name, selected portion ID, price

Function 3: **SENSORS ON / OFF** **NO**

- Turn the key to program and back to switch sensors from ON to OFF.
- Sensors OFF disables the liquor system.
- When sensors are OFF the “pour ” and “fault” lights flash alternately.
- Turn the key to program and back to re-enable the sensors.

Function 4: **CNT 00A 000000** **NO**

- To Read counters from the display.
- Press the S button to go to the next counter.
- Press the R button to go to the previous counter

Function 5: **PROMO 00A 000000** **NO**

- To read promo counters from the display.
- Press the S button to go to the next counter.
- Press the R button to go to the previous counter

Function	Display	Serving mode
-----------------	----------------	---------------------

Function 6: **Manual/Auto Shifting** **NO**

This mode is used to change to the next period automatically at the start time of the following period programmed in the machine. Available only if more than one period has been programmed.

- Turn the key to Program
- Press the SP button to select between manual and auto shifting.

Function 7: **Manual/Auto Printing** **NO**

This mode is available if the system is set to Auto shifting. At the start time of the following period, a report will be automatically sent to the serial printer.

- Turn the key to Program
- Press the SP button to select between manual and auto printing.

Function 8: **Current period : 3** **NO**

- Displays the current period selected.
- The number of periods and their times must be programmed first.
- To change the period manually, turn the key to program.
- Press the S or R button to select another period.
- Turn the key back to the vertical position.

Function 9: **PRINT REPORT ?** **NO**

- Press « SP » to print a report.

Function 10: **CLEAR COUNTERS ?** **NO**

- Immediately after printing a report, the Eclipse will ask you if you wish to clear the counters.
- Turn the key to Program and back to clear the counters.
- Press « M » if you wish to go on without clearing the counters.
- The counters for the 3 available periods will be cleared.
- NEVER CLEAR THE COUNTERS WHEN USING THE SOFTWARE TO READ THE COUNTERS.

4.3. Using the Eclipse

As opposed to other types of pour spout readers; barcodes are read as the pour spout is being inserted into the activator ring. When the barcode passes in front of the optic sensors located at the base of the activator ring, the Eclipse takes two separate pictures of the barcodes, one from each sensor. The pictures are then analyzed by the Eclipse to validate the code. If either one of the barcode pictures is validated, the Eclipse will turn the green Pour light on. The display will show the pour spout number with the corresponding pour size information.

Sequence of events

The Eclipse knows when to start taking the pictures when the first silver bar at the top of the barcode passes in front of the sensors. This happens when the pour spout is more than half way inserted.

From this moment on, until the pour spout is fully inserted into the activator ring, the Eclipse registers the sequence of black and silver bars transmitted by the optic sensors. You cannot stop during this short time since you would alter the sequence of the barcode.

The speed at which the barcode passes in front of the sensors can vary up to a point. If the passing of the barcode is too slow, the Eclipse will run out of memory to store the pictures and give you a fault. If the barcode moves too fast in front of the optic sensors, the system will not be able to differentiate the large and narrow bars and give you a fault. Under normal operating conditions, the Eclipse will easily read the barcode.

The Eclipse validates the code once the pour spout is fully inserted. This process takes a few milliseconds.

The silver space at the bottom of the label between the last black bar and the top of the number is used by the Eclipse to verify that the bottle is in position. There is enough space there to allow for considerable movement of the activator ring without loosing the code. This silver space must remain clear of any markings that could confuse the Eclipse.

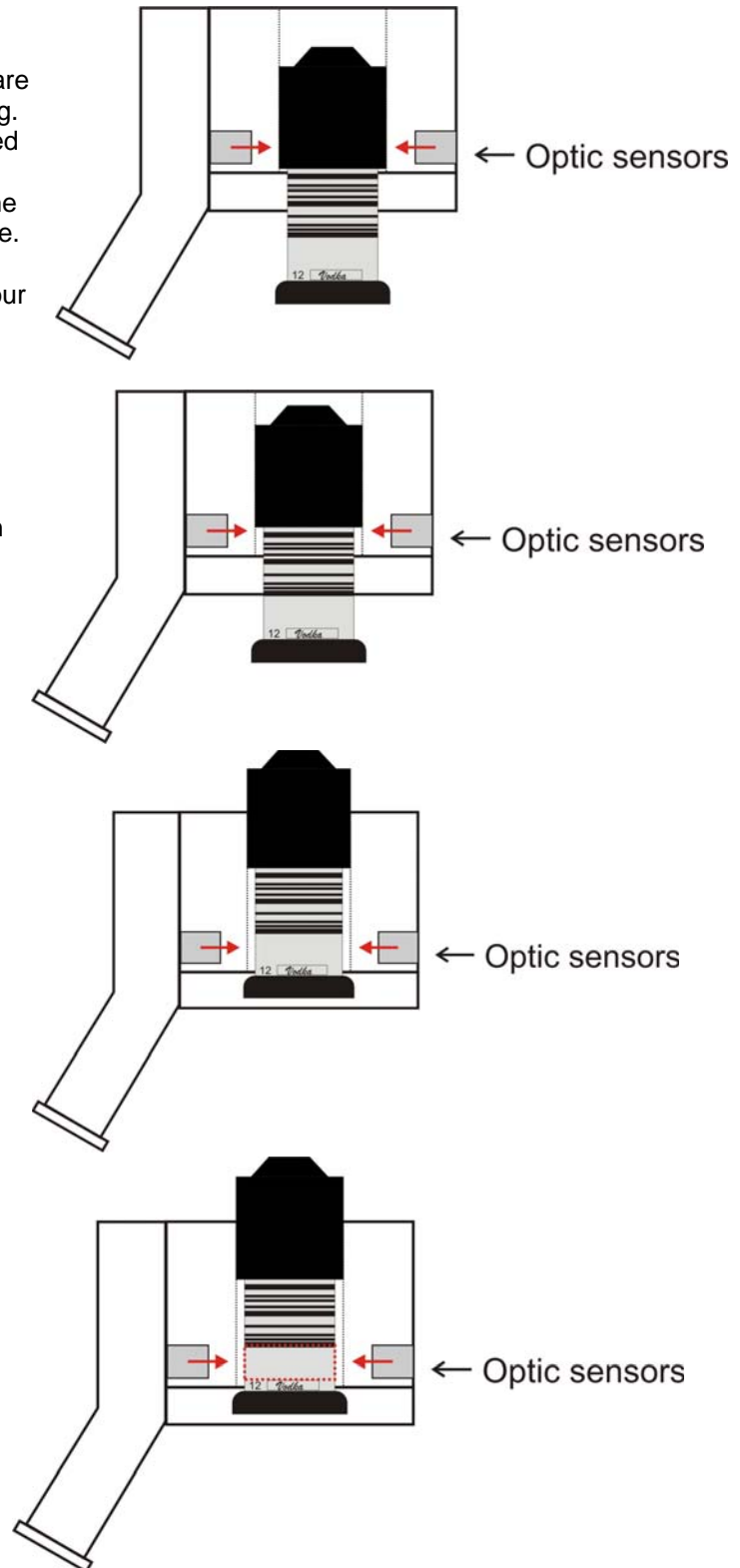

4.4. Pour spout operation

When you invert the activator ring and bottle to pour a drink, the Eclipse opens the valve inside the pour spout. Gravity pushes the liquid down and air is sucked inside the bottle. If the air intake is restricted or blocked, the liquid will not flow out of the bottle freely.

The breather apparatus is composed of two check valves. The check valves must operate freely to allow air to flow inside the bottle and block liquid from flowing out through the air vent cavity. The air vent channel must be cleaned at the same time you clean the pour spouts as described in the Eclipse maintenance video supplied with the system.

When the pour size timer is complete, the Eclipse shuts the valve off. A timer setting (TMR) of 40 equals approximately 30 ml depending of the viscosity of the liquid. If you have problems with pour sizes, it is most likely caused by an airflow restriction.

When you hold the bottle and activator ring at the recommended operating angle of 45 to 60 degrees, the cavity above the valve will empty itself in the glass right after the valve is closed thus helping you keep your system and work environment clean. This feature is a definite advantage considering that the trapped liquor on conventional pour spouts will escape at the first abrupt movement and spill everywhere. If you hold the bottle upside down, the cavity will not empty in the glass and your pour spout will act as any other pour spout retaining liquor at the tip.

- **Always terminate the pour sizes and allow the last drops to pour in the glass.**
- **If a pour size needs to be reduced, please ask the bar manager to adjust it to the correct level.**

Fruit flies:

Fruit flies will not penetrate bottles equipped with these pour spouts from the top. If you use the system as per our recommendation, the top ends of your pour spouts will not contain much more than a drop of liquor as opposed to what would be the equivalent of a swimming pool for a fruit fly. Since liquid cannot come out, flies cannot go in. Fruit flies will find their way inside the bottle through the air vent channel. To prevent fruit flies to enter this cavity, we are now installing a small screen at the entry of the air vent channel. The screens are available to retrofit on older pour spouts models.

Normal wear

Check the seal between the pour spout and the bottleneck. As corks will wear out, it is important to replace them for new ones from time to time. The breather tubes can become loose with time. New tubes are available to install on the check valves as well as the complete replacement breather tube apparatus.

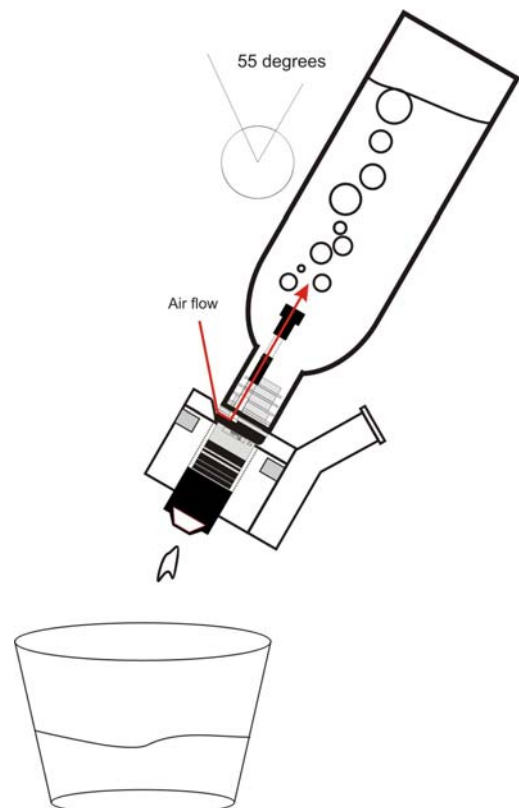
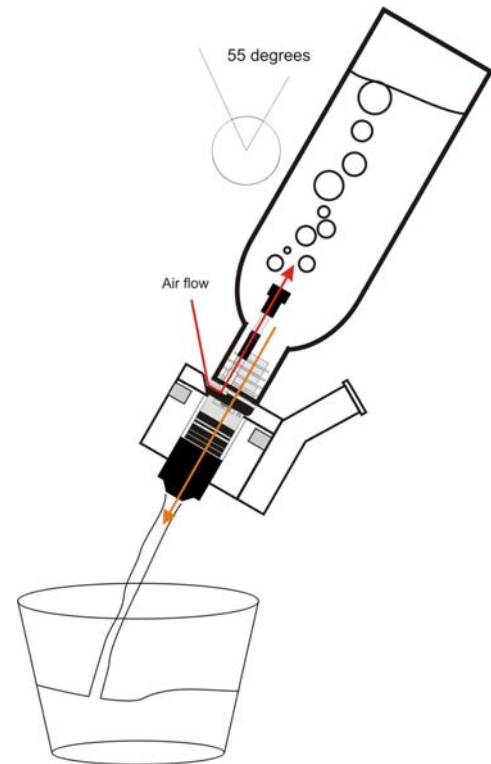

5. Installing the printer

If you are using a printer supplied by Auper Electronic Controls Inc, the printer settings have been set at the factory and the cable is already installed. Your printer is ready to be connected to the 9 pins null modem Rs-232 port.

5.1. Printer settings:

1. Baud rate: 9600
2. Data bits: 8
3. Stop bits: 1
4. Corrupt data: not checked
5. Flow control: Xon/Xoff
6. Characters per line: at least 40

5.2. Serial printer cable pin out

DB9	DB25
2 -----	2
3 -----	3
5 -----	7

5.3. Multi-system selector switch

2 or 3 Eclipse systems can be connected to the same printer using the Rs-232 port and a selector switch. The switch must be turned to the position corresponding to the Eclipse system that you want to print a report from prior to sending the report. 9 pins serial switches are available at office furniture and computer stores or can be ordered as a special order item from Auper Electronic Controls Inc.

6. Selecting the serial port

- RS-232 for distances up to 100 feet (30 meters) between the Eclipse and computer.
- RS-422 for distances up to 3330 feet (1000 meters) between the Eclipse and computer.
- To connect up to 5 Eclipse liquor systems in the same bar to the same computer, use the Auper Rs-422 port and a 5-way splitter (part # 70-065) with the Rs-422/Rs-232 converter at the computer end.



9 pins serial ports



SRP-270

DOT-MATRIX RECEIPT PRINTER

High durability dot-matrix printer is the smart choice for PC or POS systems.

The new Samsung SRP-270 series two-color dot-matrix printer combines high reliability and high print quality with low cost of ownership. The SRP-270 is an ideal printer to install in any environment with high volume and high quality requirements. Customers can select from three SRP-270 models (SRP-270A manual tear; SRP-270C auto-cutter; SRP-270D auto-cutter with paper take-up). The SRP-270 offers a compact design in two different cabinet colors (chic white and dark gray). The SRP-270 features the most current interface options including serial, parallel, RS-485 and USB.

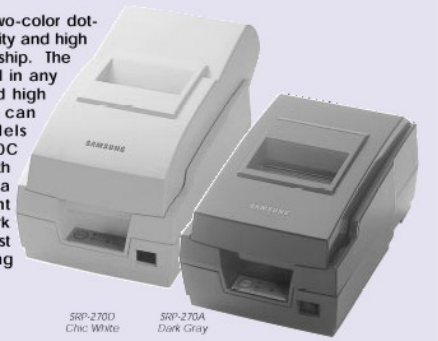

SRP-270D
Chic White

SRP-270A
Dark Gray

- To connect several Eclipse stations from different bars use the Auper Rs-422 hub and converter kit to connect up to 8 stations and obtain a single output (see networking section).
- To change the port selection set by default at the factory to Rs-232, slide the switch located at the back of the Eclipse towards the Rs-422 position.
- Sliding the switch toward the modular connector (phone jack) will set the serial port to RS-422.
- Sliding the switch away from the modular jack will set the port for RS-232.

6.1. Serial communication cables

Rs-232 cable

If the distance is less than 100 feet (30 meters), you should use an Rs-232 null modem cable. This is a 9-pin female to 9-pin female cable with the following pin out:

DB9F		DB9F
2	-----	3
3	-----	2
5	-----	5

- **Solder pins 7 to 8 and 4 to 6 on both sides.**

Your computer's serial ports are identified as COM 1 and COM 2. The connectors are 9 pins male connectors.

Rs-422 cable

If the distance is greater than 100 feet (30 meters), you must use Rs-422 cables that are terminated by modular jacks (telephone connectors). The Rs-422 protocol is not compatible with your computer. You must install an Rs-422/Rs-232 converter at the computer (see networking section).

Straight Rs-422 cables

A straight Rs-422 cable is a 2 twisted pair cable (rigid) terminated by modular jacks. These cables can be ordered pre-tested from the factory. You can use these cables to connect one system to a computer. The connectors should be covered to protect them when passing the cables.

We recommend using data/voice outlets at both ends of a Cat 5 cable linking a bar with the office. Modular cables are used to connect the systems to the data/voice outlets. (see diagram in the network section)

7. Networking Eclipse systems

Both the Auper Harpagon flow meter system and the Eclipse liquor dispenser can be interfaced to your computer. Given the great difference in the type of data generated by the systems, we have two different software: Draft Manager for the Harpagon and Liquor Manager for the Eclipse Hv 100. The software can share the same serial port on your computer, which provides for the ability to network both systems. Up to 100 systems can be networked to one computer. To link more than one Harpagon or Eclipse Hv 100 systems, you must use the Auper 8 input Rs-422 stackable hub (part No: 70-060). All network transmissions use the Rs-422 protocol. At the computer end of the network, the Auper Rs-422 to Rs-232 converter (part No: 70-050) is necessary to convert the signals coming from the Rs-422 network into the Rs-232 format compatible with your computer's 9 pins serial port. Order at least one Rs-422 hub and Rs-422/Rs-232 converter kit (Part No.70-000). Additional hubs can be ordered separately (Part No. 70-060)

7.1. Rs-422 Hub

The output of one hub can be connected to any one of the 8 inputs of another hub to enlarge your network. Any number of hubs can be used this way. Up to 1000 meters can separate two Auper devices using the Rs-422 protocol. Each Eclipse or

Harpagon system on the network must be set to use the Rs-422 port as explained in the corresponding manuals.

7.2. Modular splitters

The Eclipse is equipped with a special device, which will allow the use of Rs-422 splitters in bars where more than one Eclipse Hv 100 stations are installed. The splitters may only be used for short distances and cannot be used to link several bars to the same computer. Use the Rs-422 hub in the office to link all your systems to the computer.

Splitters cannot be used with the Harpagon system.

7.3. Using Data/Voice Outlets

Two types of cables are involved when planning the installation of an Rs-422 network. Modular cables are used between each device and a Data/Voice outlet (Part No.70-070) or from the hub to the converter. Twisted pairs Cat 5 network cable (or standard 2 pair telephone cables) are used to link each bar or storage rooms where the systems are installed, to the office where the computer with the software is. The Rs-422 transmission protocol uses two twisted pairs. A standard Cat 5 cable has 4 twisted pairs. One Cat 5 cable can accommodate two Rs-422 transmissions. Long modular cables should be avoided.



Rs-422/Rs-232 converter



Rs-422 stackable hub



Modular cable

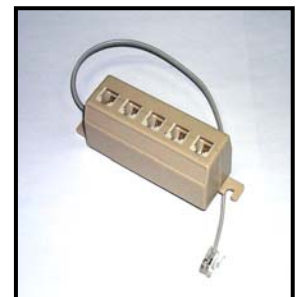

5 lines Rs-422 splitter



Data/voice outlet

7.4. Ordering the cables

A. Eclipse Hv 100

- Order one Cat 5 cable with two data/voice outlets (one at each end of the cable) for each bar you wish to link to the office.
- One modular cable per Eclipse Hv 100 system installed at each bar is necessary.
- For bars with more than one Eclipse systems, you will need to order one 5-line splitter (Part No.70-065).
- One modular cable per Cat 5 cable coming into the office is necessary to link the data/voice outlets to the hub.
- One modular cable is required to link the hub to the converter. Please specify the length of each cable when ordering the equipment.

B. Harpagon flow meter systems

If several Harpagon systems are installed in the storeroom area, two options are available to link them to the network.

Option 1: One hub can be installed at the location where the Harpagon systems are installed to link them all together and come out of the hub with only one cable. The outlet of the hub is then connected to a Cat 5 cable going to the office.

- Order one Cat 5 cable with two data/voice outlets (one at each end of the cable) for each storeroom you wish to link to the office.
- One modular cable per Harpagon to link it to the hub is necessary.
- One modular cable is required to link the hub to the data/voice outlet.
- One modular cable is required to link the office hub to the converter. Please specify the length of each cable when ordering the equipment.

Option 2: Each Harpagon can be connected to a Cat 5 cable with data/voice outlets going to the office and only one hub is used to link all the systems together. Each Cat 5 cable can do 2 Harpagon systems. This option is valid if no more than 8 Auper systems are used on the network and if passing extra Cat 5 cables is not a problem.

- Order one Cat 5 cable for each pair of Harpagon systems with two data/voice outlets per Harpagon you wish to link to the office (one at each end of the cable).
- One modular cable per Harpagon to link it to the data/voice outlet is necessary.
- One modular cable is required to link the office hub to the converter. Please specify the length of each cable when ordering the equipment.

7.5. Rs-422 CABLES

The modular cables supplied by Auper look like those used for telephones. As opposed to telephone cables, Rs-422 cables are always INVERTED. The Cat 5 cables connections must also be inverted between the data/voice outlets. Modular cables shipped by Auper are tagged and tested to prevent installors from mixing Rs-422 cables with telephone wires.

Rs-422 protocol 4-wire connections : Tx+, Tx-, Rx-, Rx+

1. Yellow wire Tx+ to black wire Rx+
2. Red wire Tx- to green wire Rx-
3. Green wire Rx- to red wire Tx-
4. Black wire Rx+ to yellow wire Rx+

Connecting the data/voice outlets on a Cat 5 cable:

Cat 5 color code: (each white cable has a corresponding color line)

- First twisted pair: white-blue/blue
- Second twisted pair: White-orange/orange
- Third twisted pair: white-green/green
- Fourth twisted pair: white-brown/brown

Each Data/voice outlet is equipped with four screw terminals colored Black, red, green and yellow. We recommend the following cable connections.

Data/voice in		Data/voice in
Bar/storeroom	to	Office
Black to white-blue -----		Yellow
Red to Blue -----		Green
Green to White-orange -----		Red
Yellow to orange -----		Black

7.6. Network schematic

Auper Raymaster and Harpagon network schematic

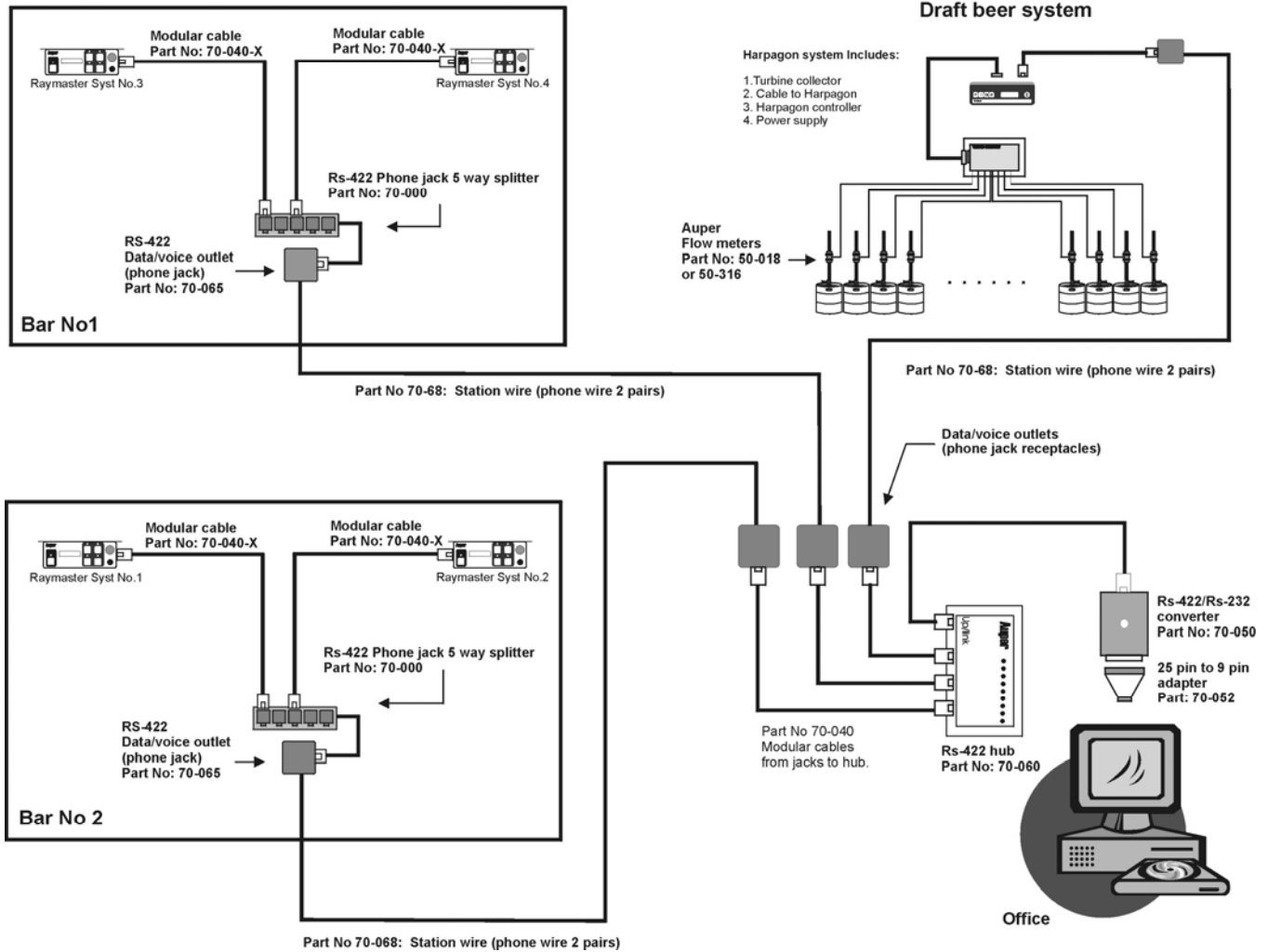

8. Interfacing the Eclipse Hv 100

Terminology used in this document:

- ❑ **POS:** Point of sales system. Usually a touch screen, PC based computerized system.
- ❑ **ECR:** Electronic Cash register
- ❑ **Eclipse:** Liquor dispenser made by Auper
- ❑ **LDS:** Liquor dispensing system
- ❑ **PLU:** Price look-up number

Interfacing a liquor system like the Eclipse is very much in demand these days. The technology is simple enough although many do not understand how it works and some may even be a little frightened by it. If you are you shouldn't be.

An interfaced Eclipse offers some very attractive advantages:

- Sales are registered automatically. Instead of looking for menus or cash register keys, the bartender pours the drink, which registers automatically identifying the category name and price. *They gain speed and mistakes are avoided.*
- No reports to look at. Since the liquor system will not dispensed the drink until it has been told to by the POS or cash register, bar managers do not have to worry about reconciling sales with usage.
- If the POS or ECR is turned off, liquor will not pour.

The Eclipse is ready to interface to most POS systems or ECRs **that have the ability** to interface to a liquor system. *That means there has to be a program in the POS or ECR to interface to a liquor system (Most POS systems do).*

When interfaced to a POS or an ECR, the Eclipse will not pour the drink before it has received the authorization to pour it from the system it is connected to. It means the POS or ECR has to acknowledge reception of the transaction data to indicate it will be handling the information from now on. Then the Eclipse dispenses the drink.

The whole process takes place in a fraction of a second.

- ❑ The liquor system is connected to the POS terminal or ECR at the bar using a standard RS-232 null modem cable.
- ❑ It is the POS software that controls the operation of the two systems together, not the liquor system. (See flow of data next)

There are two types of POS programs

1. **Automatic sales transactions**
2. **LDS suspense file**

8.1. Automatic sales transaction

The bartender must open a guest check first on the POS system. As the bartender pours drinks on the liquor system, each drink is sent to the POS where it is automatically entered on the check either as a fast transaction finalized using cash payment or, posted to a running bill. If the drink is ordered from another terminal on the floor and sent to the printer at the bar, it is usually sent with no price. The bartender will re-open the guest check at the bar's terminal to serve the drink at which time the price will be posted on the check.

8.2. LDS (liquor dispensing system) suspense file

As drinks are poured at the LDS, the LDS will automatically send debit entries to the suspense file in the POS software. As drinks are entered on the POS guest checks, credit entries are sent to the suspense file to cancel out matching debit entries sent by the LDS. At the end of the shift, the POS prints a report listing drinks poured and not posted and vice-versa.

The communication between the two systems is always the same. **It is how the POS software is designed** that will dictate if you operate with automatic sales transaction or with a suspense file. Some POS systems offer both. Ask the POS representative for details on the operation of their LDS interface.

Drink information sent by the Eclipse

The drink information sent by the Eclipse is always the same. It is a 4-digit **PLU** number when system set to 4-DIGIT PLUs = Y. A PLU is an item number and every item programmed in a POS or an ECR has its own PLU number.

It is that number which is sent to the POS. The same PLU number has to be programmed in the POS or ECR with the corresponding description and price of the drink.

There are two standard protocols used by POS software: **Berg and Micros**. Both protocols are available in the Eclipse.

- POS ENABLED (1) = BERG PROTOCOL
- POS ENABLED (2) = MICROS PROTOCOL

8.3. Flow of data

Automatic data entry

Eclipse sends PLU 0301 to POS

POS received data and looks up for PLU 0301 in its table.

If found => Description and price are posted to the check => brand name Regular @ \$4.25 and ACK signal (06) is sent to the Eclipse to pour the drink.

If NOT found => Error message is displayed on screen and NACK signal (15) is sent to the Eclipse NOT to pour the drink.

Suspense file

Eclipse sends PLU 0301 to POS

POS received data and looks up for PLU 0301 in its table.

If found => Description and price are posted to the suspense file => brand name Regular @ \$4.25 and ACK signal (06) is sent to the Eclipse to pour the drink.

If NOT found => Error message is displayed on screen and NACK signal (15) is sent to the Eclipse NOT to pour the drink.

8.4. PLU table

To program the POS or register to interface to the liquor system, Set the COM port configuration to which the Eclipse is connected with the following values:

- Baud rate: **2400 bps**
- Number of transmission bits: **8**
- Parity: **None**
- Stop bits: **1**
- Device: **Liquor (No.8 for Samsung er-650)**

The default table programmed in the Eclipse Hv 100

First two digits on the left = barcode number

Last two digits on the right = pour size No form 00 to 03

Number/size	S	R	L	SP
0	0090	0091	0092	0093
1	0100	0101	0102	0103
2	0200	0201	0202	0203
3	0300	0301	0302	0303
4	0400	0401	0402	0403
5	0500	0501	0502	0503
6	0600	0601	0602	0603
7	0700	0701	0702	0703
8	0800	0801	0802	0803

9	0900	0901	0902	0903
10	1000	1001	1002	1003
11	1100	1101	1102	1103
12	1200	1201	1202	1203
Etc...	1500	1501	1502	1503
99	9900	9901	9902	9903

The PLU table in the Eclipse Hv 100 is programmable using the Liquor Manager software.

8.5. Trouble shooting the interface

The Eclipse can be disconnected from the ECR or POS it is interfaced too in four easy steps:

- I. Turn the key to Program. The display show the first mode: [TMR 00R 0044]
- II. Press the M button once: The display shows [POS ENABLED 1]
- III. Press the SP button once to turn the interface off. The display shows [POS DISABLED]
- IV. Turn the key back to RUN.

The number besides the POS ENABLED indicates the communication protocol selected by the POS vendor. The L button can be used to change it from 1 to 3.

On POS DISABLED, the liquor system **will not** request an ACK signal from the POS or ECR to pour the drink. The Eclipse is now operating as a stand-alone device. This is how you must test the liquor system.

8.6. Testing the liquor system

- A. Insert a spout in the activator ring and select a pour size. Make sure you get the green light.
- B. Turn the key to Program. The display shows {TMR XXR 0044}. XX is the spout number you just inserted.
- C. The number on the right indicates the timer setting for this spout and pour size. If this number is zero, the portion has been turned off. A setting of approximately "40" indicates a portion of 30 ml (1oz).
- D. You can activate (above 0) or change the portion size by using the L and SP buttons.
- E. Now that you have verified there is a portion setting, turn the key back to the horizontal position.
- F. Invert the ring to pour. If the drink pours normally, repeat these steps for other spouts you had problems with.
- G. If the drink does not pour as expected, call your Auper distributor for service.

If you have established that the Eclipse is pouring normally without the interface it means:

1. There probably is a discrepancy between the PLUs programmed in the Eclipse and the ones programmed in the POS. If a PLU sent by the Eclipse does not exist in the POS, the POS cannot give the authorization to pour the drink. Call your POS or ECR vendor for verification.
2. The cable or connection between the two systems is disconnected or defective.
3. The protocol originally selected was changed or is incorrect.

To re-enable the interface:

- V. Turn the key to Program. The display shows the first mode: [TMR 00R 0044]
- VI. Press the M button once: The display shows [POS DISABLED]
- VII. Press the SP button once to turn the interface off. The display shows [POS ENABLED 1]
- VIII. Turn the key back to the horizontal position.

9. Maintenance

In order to perform to its full potential, a liquor system requires a minimum of maintenance. To neglect the daily maintenance will eventually lead to dispensing problems. The Eclipse activator ring is a sophisticated electronic barcode decoder. It must be kept clean in order for the optical system to work properly. The ring should always be put back on its support after use and never used for any other purpose (break ice for example).

9.1. Dispensing liqueurs

Liqueurs are by nature stickier. Brands that sell fast will not create additional problems as long as the normal maintenance is properly done. Brands that do not sell fast will require daily "rinsing". Irish cream will always require daily rinsing because of the cream it contains.

What happens: The sugars left in the spout when the bottle is sitting in the upright position will crystallize and prevent the valve from opening and/or closing properly. Some products will dry up faster than others. To prevent dispensing problems associated with the crystallization of the sugars, you need to melt the sugars with **hot** water.

9.2. Rinsing pourers

Each day, before the period starts, these spouts should be rinsed under hot water for at least 20 to 30 seconds. The spout stays on the bottle. The hot temperature will melt the crystallized sugars and free the valve. Allow some water to penetrate the top of the spout to rinse off any crystallized liquor (especially for Irish cream). Water will not penetrate into the bottle. Invert the bottle above the sink and shake the water off the top of the spout. Wipe the spouts and bottle with a clean rag.

The selection of bottles that will require daily rinsing will vary according to the popularity of each brand. For example, if you sell a bottle of Sambuca every 4 days, chances are that if the spouts are cleaned properly after each bottle, that you will never need to rinse them.

9.3. Cleaning pourers

We recommend using the Auper magnetic pourer cleaning (ordered separately) device to clean your pourers every time one is removed from an empty bottle. When a pourer is left on a bottle for more than 30 days, it should be removed and cleaned as well. Keep this device locked and out of reach of the bartenders as they will be able to serve liquor with it.

Step 1

- Insert the pourer inside the magnetic device.
- You should hear the pourer open.
- If the pourer remains closed, soak it in hot water for 30 minutes to dissolve the hardened sugars jamming the valve.
- Try again with the magnetic device.



Step 2

- Hold the pourer under **hot** running water for 30 seconds to clean it properly.
- The water should flow through the pourer and come out at the bottom.
- Using cold water is useless to dissolve hardened sugars in the valve mechanism.



Step 3

- Hold the pourer side ways with the air admission hole facing up.
- Let water in the air admission hole to clean the breather tube and the check valves.
- Water should come out at the end of the breather tube as shown on the third picture.

9.4. Testing pourers

- You can check if a pourer seals well by inverting a full bottle or by trying to suck air from the top. If it leaks, clean it again or replace it.
- To test a breather tube, you can remove it from the pourer.
 - You should be able to blow air through it.
 - You should not be able to suck air through it as the check valves blocks air and liquid circulating in this direction.
 - Always wash a pourer after testing it with your mouth.
- Always check that the cork does not leak any liquor. If it does, replace it.

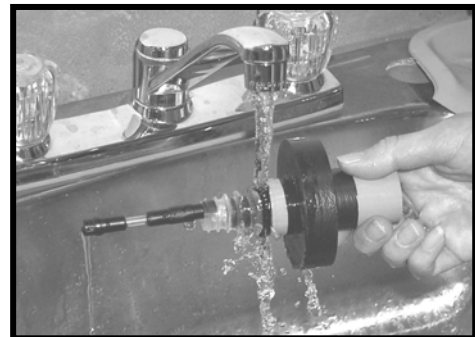

9.5. Activator ring maintenance

A bottle of alcohol and a box of Q-tips should be kept in the bar at all times. The activator ring should be cleaned daily. It is easy to skip a few days and forget about the maintenance since it will take some times before the systems starts having difficulties reading the barcodes. But it will eventually catch up with you and the resulting problem is that your bartenders may have to insert a pourer several times before the system can actually identify the barcode. It is a waste of time that can be prevented by making the cleaning of the sensors a daily routine.

Use a **clean and humid rag** and wipe the activator ring and cable clean of any dried liquor residue. With a clean cotton swab (Q-Tips) soaked in rubbing alcohol, clean both lenses inside the ring.

Tip:

Use the small angles mirror supplied with the system to check your sensors regularly.

- **NEVER submerge the activator ring or clean it under running water.**
- **NEVER use industrial or domestic detergent to clean the activator ring. (Ex: “Fantastic” will damage the glass lenses.)**
- **NEVER hit the activator ring or use it to break ice. (This would temporarily fragment the tilt switch rendering the system unusable for a while)**

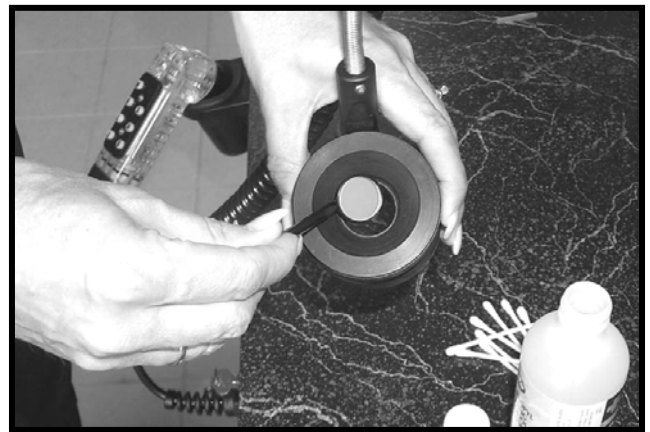
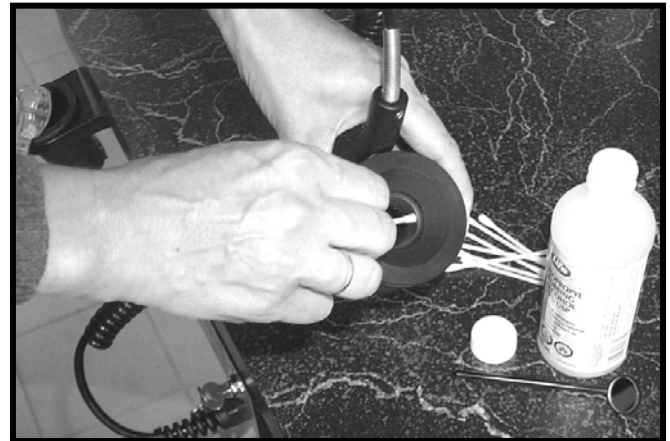

10. Part list

<u>Part number</u>	<u>Description</u>
System	
80-Hv100-LM-K	Eclipse Hv-100 complete system with Liquor Manager
80-Hv100	Eclipse Hv-100 monitor only
40-010	Eclipse power supply 24V 40VA
80-300	Y bracket for activator ring
80-710	Liquor Manager Software
70-005	Eclipse 4' extension cable
30-225	Mounting bracket w/screws for extension (2)
70-010	Rs-232 communication cable (DB9M-M)
Accessories	
80-005	Pourer
80-015	Security seals (set of 1000)
80-025	Reflective barcode set of 5 sheets (no. 0-99)
80-030	Reflective barcode 1 sheet (no.0-8)
80-031	Reflective barcode 1 sheet (no.9-22)
80-032	Reflective barcode 1 sheet (no.19-45)
80-033	Reflective barcode 1 sheet (no.46-72)
80-034	Reflective barcode 1 sheet (no.73-99)
80-805	Regular clear poly cork (10)
80-010	Lifted pourer 1800
80-810	Large size red cork (10)
80-815	Extra large size beige cork (10)
80-825	Pourer cleaning device
80-840	Cleaning kit (alcohol, Q-Tips & mirror)
70-400	Samsung serial printer
70-410	Serial printer cable 10 ft (DB9F/DB25M)
Networking & communication accessories	
70-000	Rs-422 Hub & Rs-422/Rs-232 Converter Kit
70-051	Rs-422/Rs-232 Converter w/power supply
70-060	Rs-422 Hub only
55-U-050	Power supply for hub
70-040	Modular cable 10ft
70-040-X	Extra length of modular cable
70-065	2 way modular splitter
70-070	Data/voice outlet
70-068	Two par station wire
70-045	Gender changer DB25 M/M
70-046	Gender changer DB9 M/M
70-055	DB25 to DB9 Adaptor
70-430	Data selector switch
Replacement parts	
80-040	Replacement breather tubes (10)
80-066	Replacement breather tube top straw (10)
80-067	Replacement breather tube bottom straw (10)
KEY-2007	Extra key
55-R-065	3 V battery
Manuals & instructions sheets	
80-855-CD	Eclipse maintenance video on CD
I80Hv100E (I80Hv100F)	Eclipse Hv100 User guide English (French)

11. Hardware Warranty

Auper Electronic Controls Inc. warrants that this product is in good working condition, according to its specifications at the time of the shipment, for a period of one (1) year from the date of purchase. Should the product, in Auper Electronic Controls Inc opinion, malfunction within the warranty period, Auper Electronic Controls Inc. will repair or replace the product without charge. Any replaced parts become the property of Auper Electronic Controls Inc. This warranty does not apply to the software component of a product or a product which has been damaged due to an accident, misuse, abuse, improper installation, usage not in accordance with product specifications and instructions, natural or personal disaster or unauthorized alterations, repairs or modifications.

LIMITATIONS

All warranty for this product, expressed or implied, are limited to one year from the date of purchase and no warranty, expressed or implied, will apply after that period.

No warranties for this product expressed or implied will apply to any person who purchases the product in used condition.

The liability of Auper Electronic Controls Inc. with respect to any defective product will be limited to the repair or replacement of such product.

In no event shall Auper Electronic Controls Inc be responsible or liable for any damages arising

(a) from the use of the product;

(b) from the loss of use, revenue or profit of the product; or

(c) as a result of any event, circumstances, action or abuse beyond the control of Auper Electronic Controls Inc.; whether such damage be direct, indirect, consequential, special or otherwise and whether such damages are incurred by the person to whom this warranty extends or a third party.

12. Annexe: PROGRAMMING AND OPERATING FLOW CHART



PROGRAM MODE

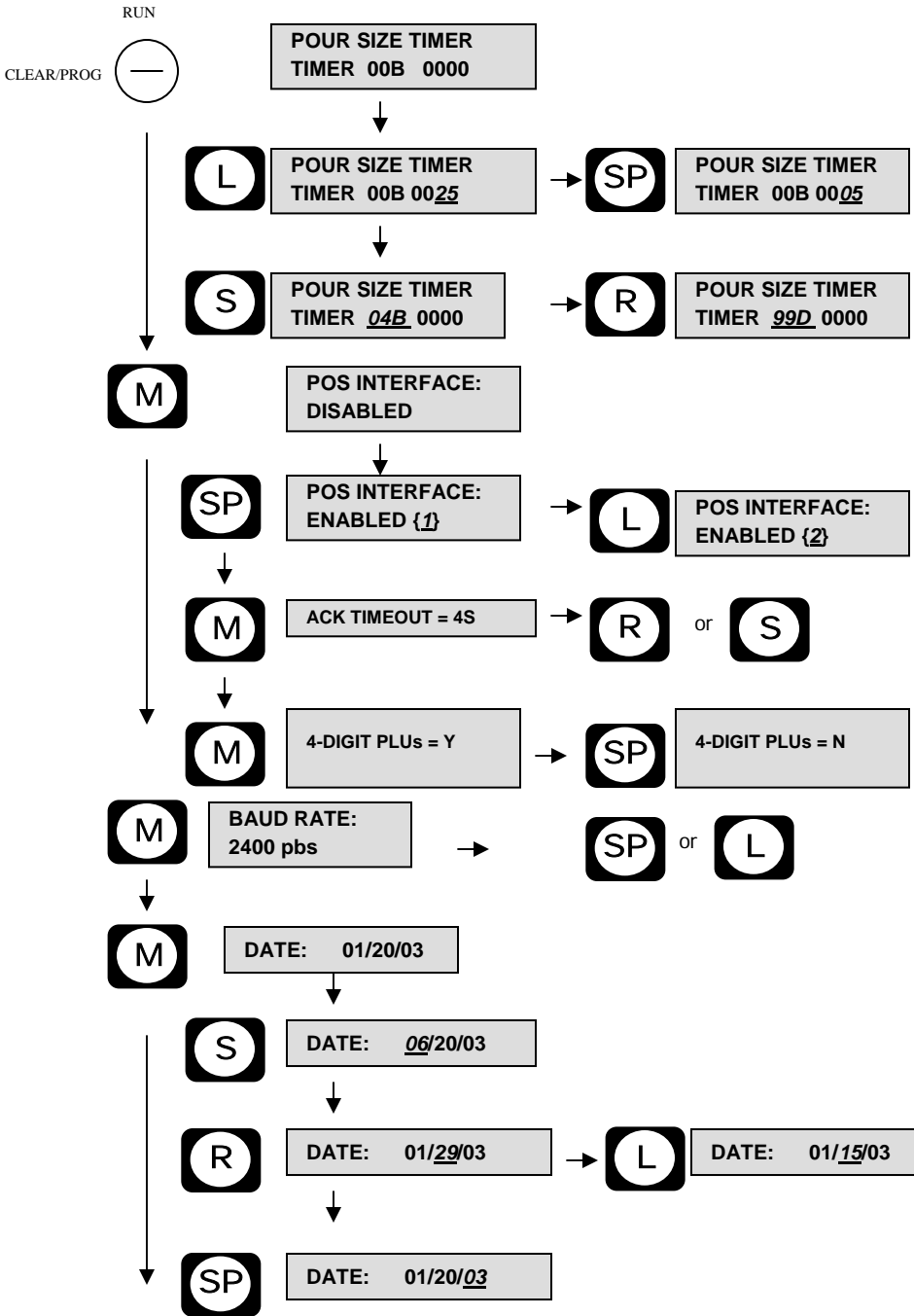

Description

- Turn the Key to its horizontal position.**
TMR = timer. Use this mode to set the timer value for each spout number and size.
To increase and decrease the timer value.
- To select spout number and shot size.
- To enable or disable the POS INTERFACE MODE.
- To select the POS protocol. (1-3)
- To increase or decrease ACK timeout delay in seconds
- To select the number of digits you are using on your PLUs.
- To select the communication baud rate (2400, 9600 or 19.2K)
- To set date.**
- To change the month going up.
- To change the day going up and down.
- To change the year going up.



PROGRAM MODE

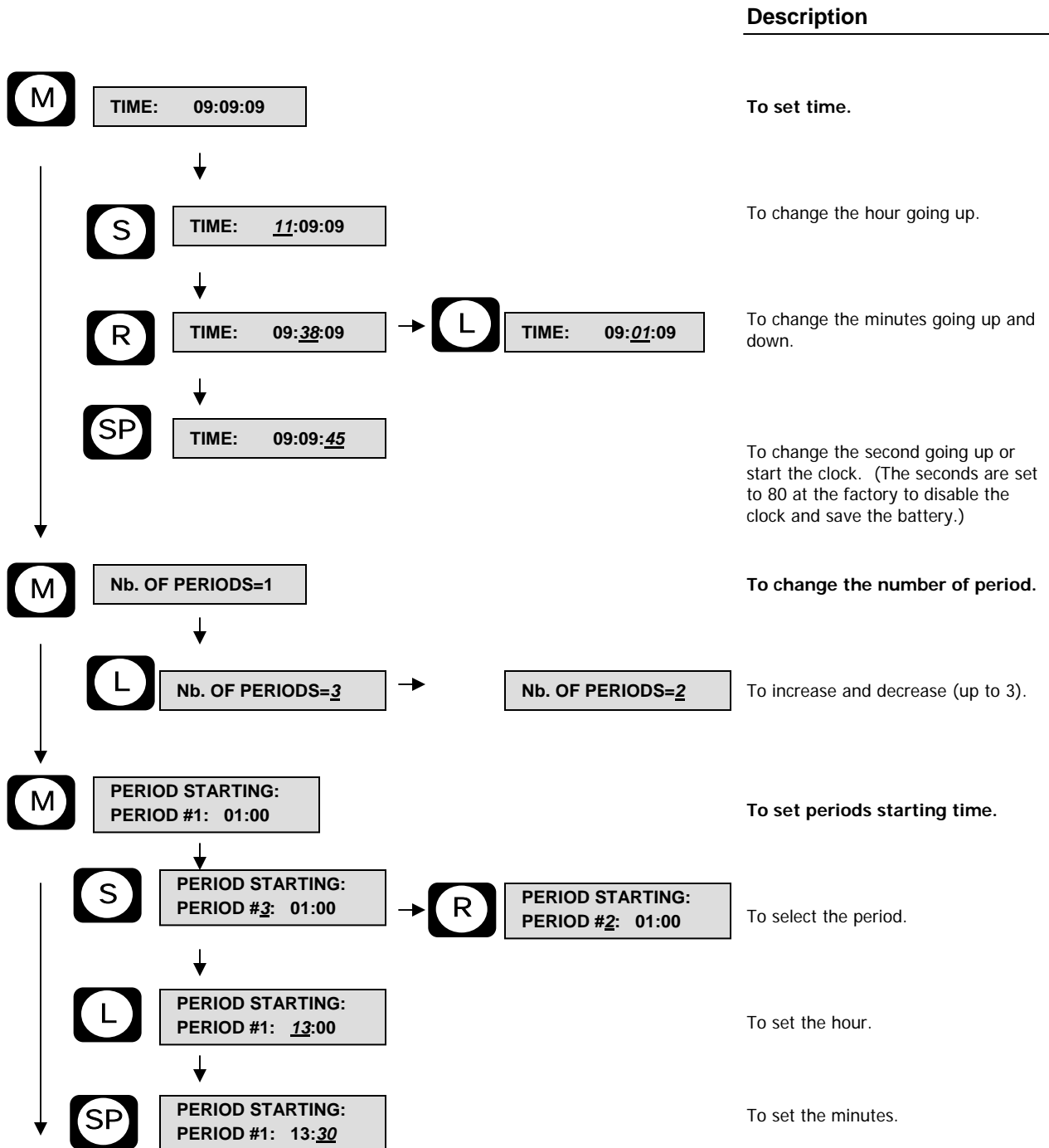



PROGRAM MODE

Description

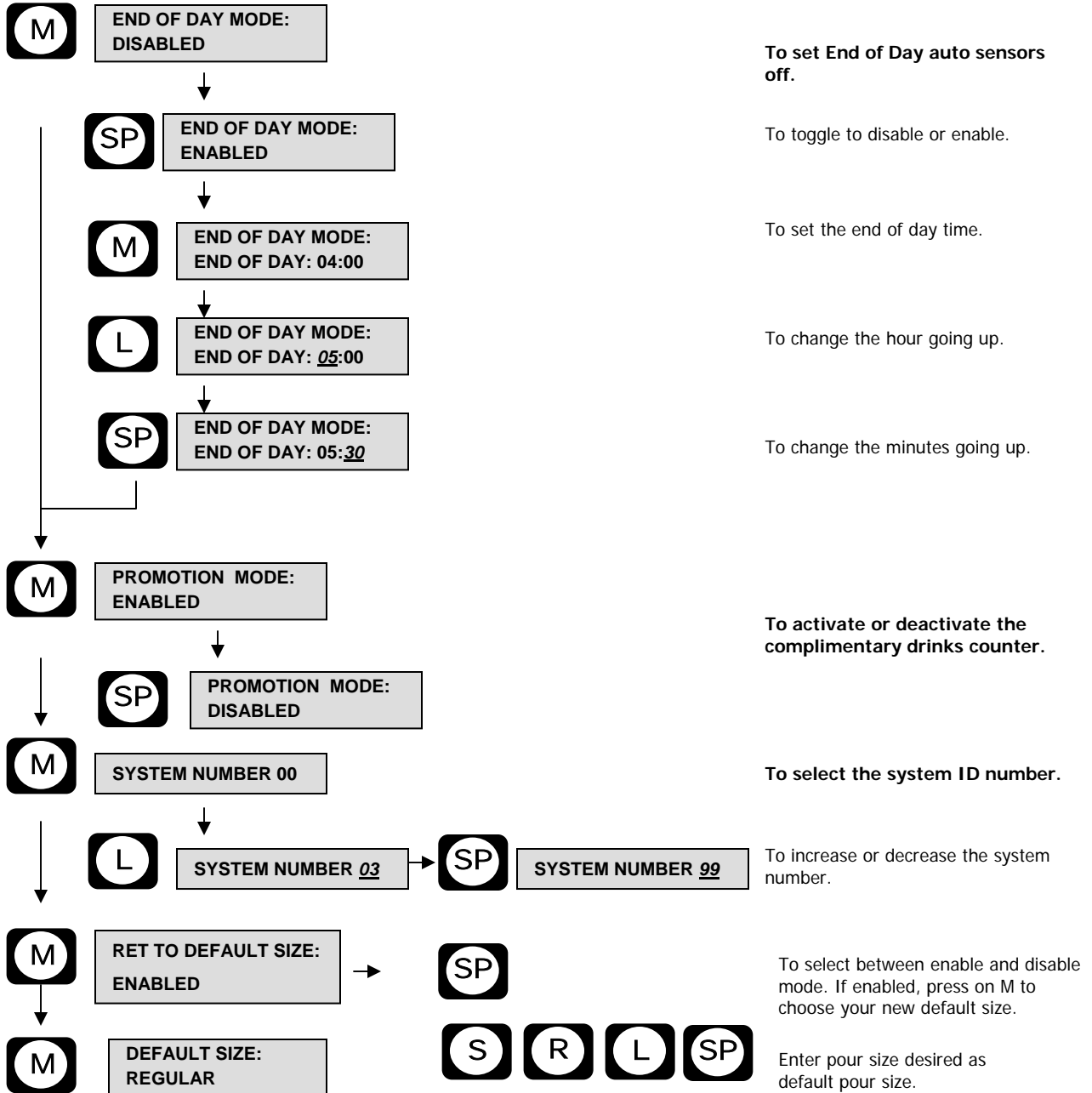

To set End of Day auto sensors off.

To toggle to disable or enable.

To set the end of day time.

To change the hour going up.

To change the minutes going up.

To activate or deactivate the complimentary drinks counter.

To select the system ID number.

To increase or decrease the system number.

To select between enable and disable mode. If enabled, press on M to choose your new default size.

Enter pour size desired as default pour size.

Program mode is complete. Pressing M will loop back at Pour size timer. Turn key to RUN mode.



ECLIPSE Hv100 VERSION 1.1 PROGRAMMING AND OPERATION MODES

FLOW CHART FC80HV100

RUN MODE

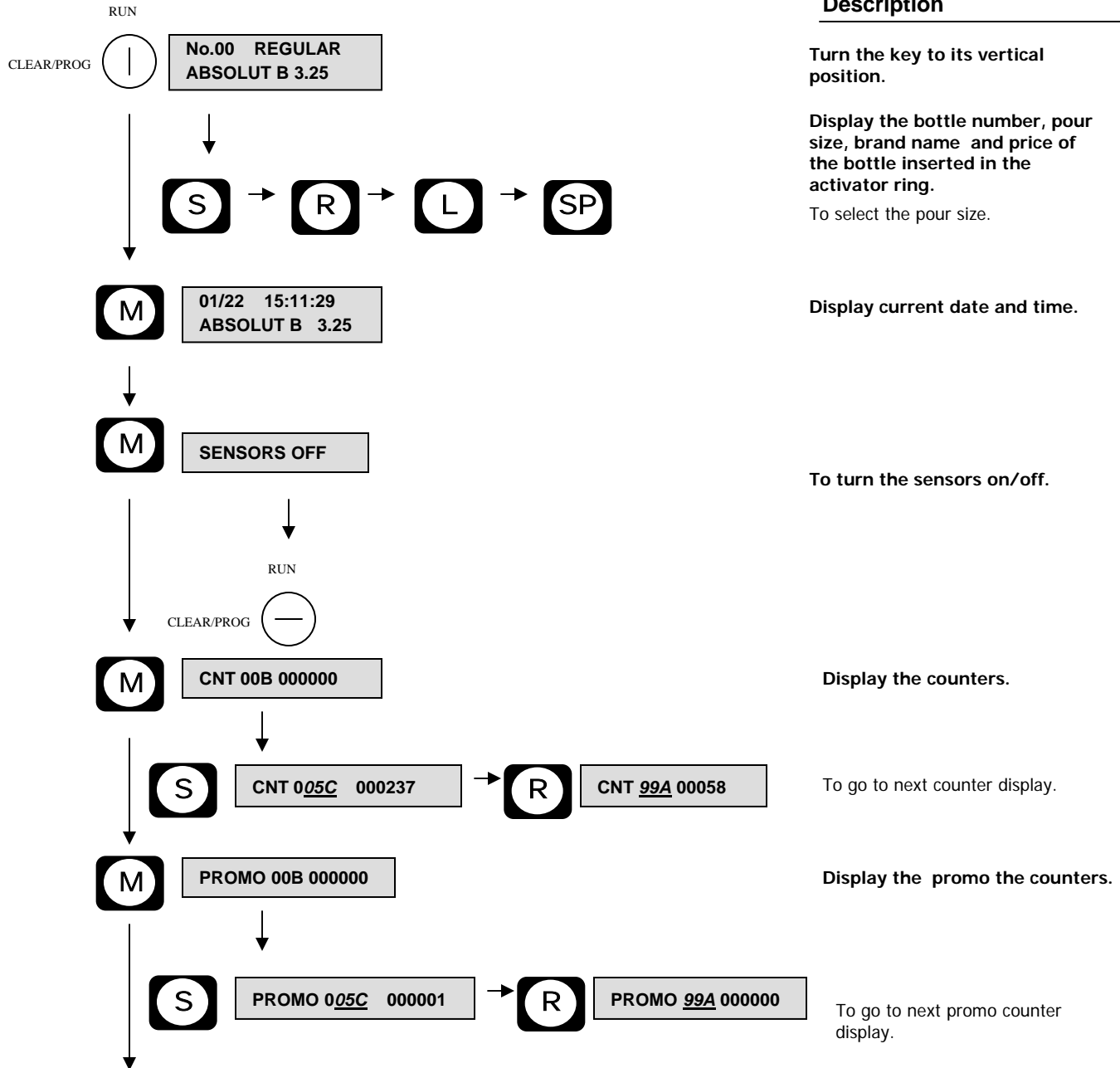



RUN MODE

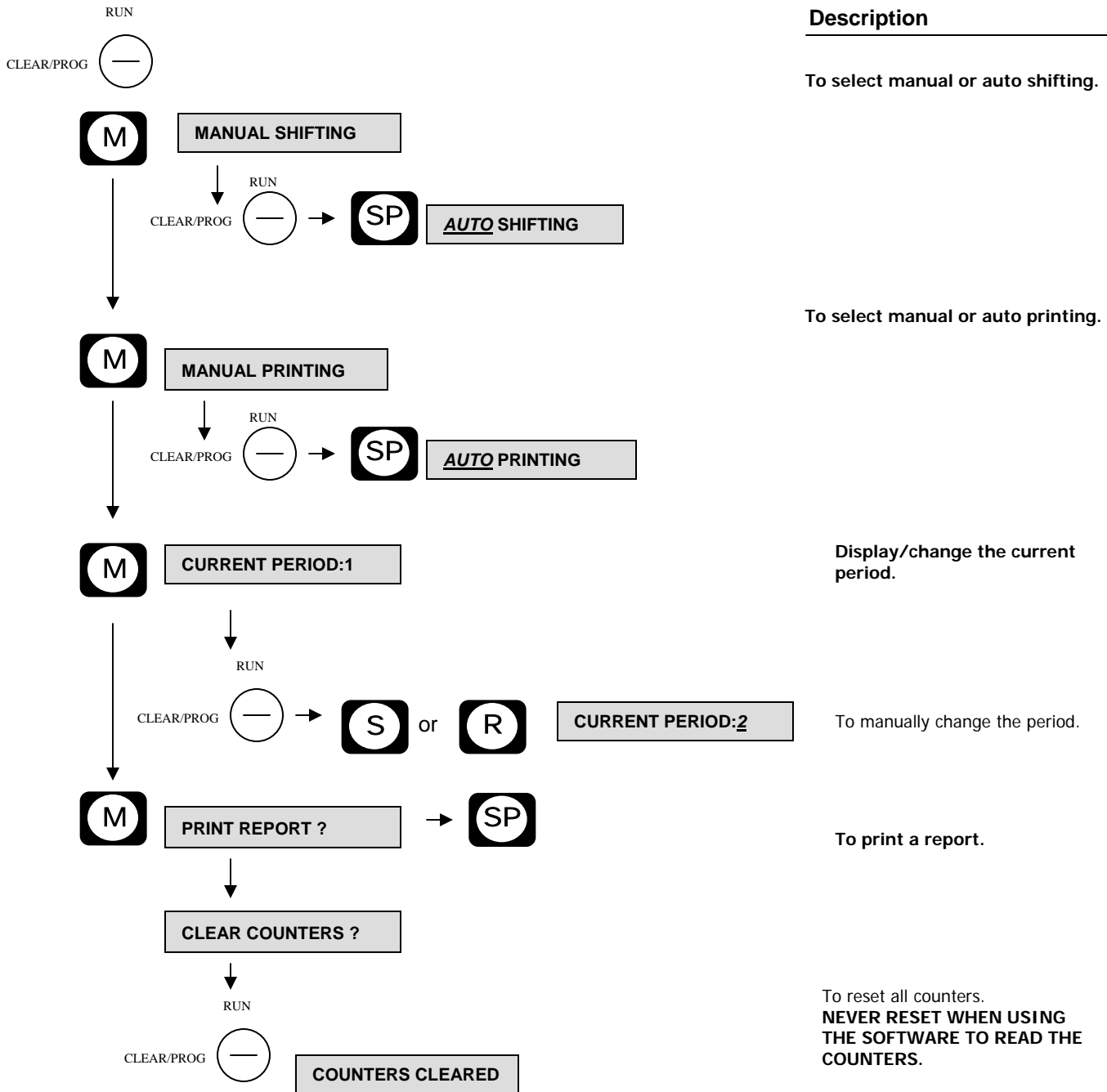

Auper Electronic Controls Inc.
901 Michelin Street
Laval – Quebec - Canada - H7L 5B6
Phone 450.663.1993 – Fax 450.663.0636
1.800.861.1620
www.bar-controls.com