

# Harpagon Real time draught beer and beverages metering system

Celebrating its 20th birthday in 2012.

You can connect up to 16 Auper flow meters to the Harpagon system. The flow meters are connected to the Harpagon system using the Auper flow meter collector box.

The system registers the amount of product dispensed in real time for up to sixteen (16) flavors. If you are not using the software, counters can be read directly from the liquid crystal display and cleared using the key.

The Harpagon can be programmed to measure ounces, liters, glasses or any other measuring unit of your choice. It is equipped with a power failure counter to indicate if the system was disconnected. In case of a power failure, the counters are saved in a flash memory.

Harpagon system includes:

- Harpagon metering system
- Flow meter collector box
- 25 ft (3M) Cat 5 network cable
- 10 ft(3M) Null modem RS-232 cable
- Draft Manager software
- 12 volts power supply



Flow meters and FOBs in beer cooler with cables going to the collector box.

## Flow meter collector box (included)

The flow meter collector box is one of the great features of the Harpagon system. It was designed to help save on installation time and prevent confusion with cables. It is estimated that the collector box configuration will cut installation time by at least 50% over traditional wiring methods. Auper flow meters come with a 25 ft (7.6 M ) cable ready to connect to the collector box. There is no crimping of connectors or multiple pair cable installation. The collector box should be installed in the keg room within reach of the flow meters assigned to it. A Cat 5 network cable for each collector box is necessary to link it to a Harpagon system. There is no external power source needed. The collector is powered directly by the Harpagon system through the network cable. The cable can be up to 300 M long terminated at both ends with RJ45 jacks. Longer cables can be ordered separately or made on site.

## Serial ports

Harpagon is equipped with two serial ports. Select the RS-232 port to connect one Harpagon system to your computer at a distance of no more than 100 feet (30 m). Use the RS-422 port if the distance between the Harpagon and the computer is greater than 100 feet (30m) or when connecting several systems to the same computer. The Draft Manager software can communicate with 100 Harpagon systems, 4FM or TM200 metering systems using AP821 hubs.

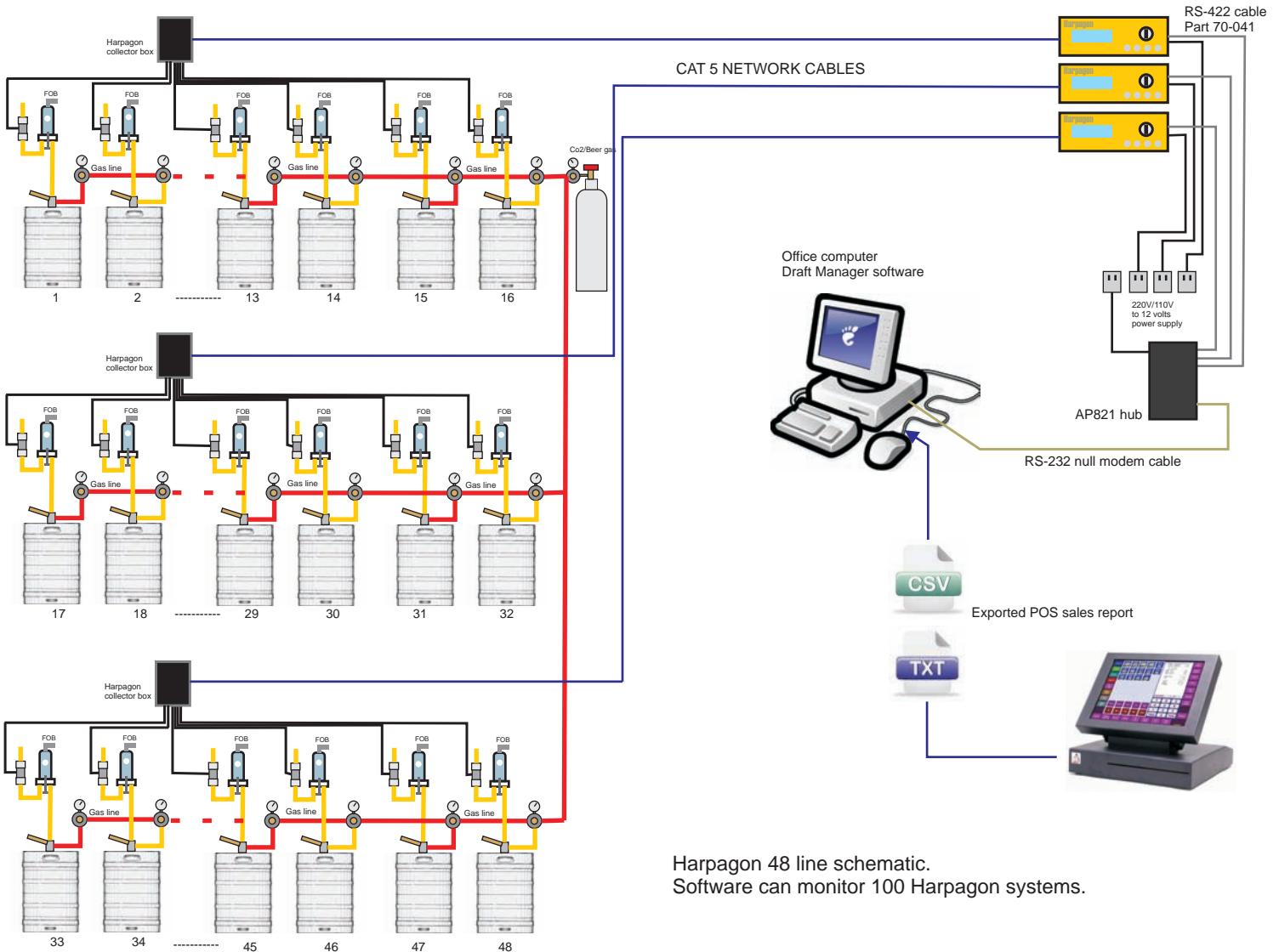

Harpagon 48 line schematic.  
Software can monitor 100 Harpagon systems.

**Specifications:**

- Power:** 12 volts AC 50-60 Hz @ 800 ma
- Harpagon Size:** 7" W X 5.375" L X 2.25" H (177.8mm X 136.5mm X 57.1 mm)
- Collector size:** 6.75" L X 4.375" W X 1.75" H (171.4mm X 111.1mm X 44.4 mm)
- Shipping weight:** 4.5 lbs / 2.04 kg @ 13" X 10" X 5" (33 cm X 25.4 cm X 12.7 cm)
- Max collector cable length:** 1000 ft / 300 m
- Max flow meter cable length:** 1000 ft / 300 m



48 flow meter installation with 3 collector boxes mounted in the beer cooler. White network cables going to the manager's office to connect to the Harpagon systems.

Sample of a Draft Manager sales reconciliation report

| Product          | Qty sold       | Qty poured     | Sales \$      | \$ Cost       | Qty diff.    | % Loss      | % Correct. | Qty Owed      | \$ Owed      | % Cost       | % Target     | % Var       |
|------------------|----------------|----------------|---------------|---------------|--------------|-------------|------------|---------------|--------------|--------------|--------------|-------------|
| Belle-Gueule Or. | 375.50         | 383.37         | 102.16        | 32.85         | 7.87         | 2.05        | 2.05       | 7.87          | 2.52         | 32.15        | 31.49        | 0.66        |
| Boreal R.        | 216.25         | 212.56         | 54.12         | 22.11         | -3.69        | -1.74       | -1.74      | 0.00          | 0.00         | 40.85        | 41.56        | -0.71       |
| Double D         | 65.75          | 130.73         | 21.09         | 15.69         | 64.98        | 49.71       | 49.71      | 64.98         | 24.04        | 74.38        | 37.41        | 36.97       |
| Tremblay         | 338.00         | 338.53         | 92.16         | 29.01         | 0.53         | 0.16        | 0.16       | 0.17          | 0.17         | 31.47        | 31.43        | 0.05        |
| Lion's P         | 150.25         | 152.15         | 43.06         | 15.08         | 1.90         | 1.25        | 1.25       | 1.90          | 0.65         | 35.02        | 34.58        | 0.44        |
| St-Ambroise      | 28.25          | 28.57          | 8.04          | 2.95          | 0.32         | 1.12        | 1.12       | 0.32          | 0.10         | 36.75        | 36.34        | 0.41        |
| Blanche C        | 225.00         | 195.36         | 60.00         | 17.96         | -29.64       | -15.17      | -15.17     | 0.00          | 0.00         | 29.93        | 34.47        | -4.54       |
| New Castle       | 56.25          | 52.92          | 17.61         | 6.29          | -3.33        | -6.29       | -6.29      | 0.00          | 0.00         | 35.72        | 37.97        | -2.25       |
| Guinness         | 98.69          | 113.06         | 33.57         | 14.58         | 14.37        | 12.71       | 12.71      | 14.37         | 5.60         | 43.43        | 37.91        | 5.52        |
| Cidre            | 51.56          | 47.86          | 16.96         | 6.84          | -3.70        | -7.73       | -7.73      | 0.00          | 0.00         | 40.31        | 43.43        | -3.12       |
| Kilkenny         | 225.00         | 222.04         | 70.44         | 27.38         | -2.96        | -1.33       | -1.33      | 0.00          | 0.00         | 38.87        | 39.38        | -0.52       |
| Smithwicks       | 18.75          | 19.46          | 5.87          | 2.32          | 0.71         | 3.65        | 3.65       | 0.71          | 0.26         | 39.50        | 38.05        | 1.44        |
| Tartan           | 75.75          | 58.18          | 19.79         | 6.78          | -17.57       | -30.20      | -30.20     | 0.00          | 0.00         | 34.27        | 44.62        | -10.35      |
| Harp             | 272.00         | 298.11         | 86.84         | 35.52         | 26.11        | 8.76        | 8.76       | 26.11         | 9.66         | 40.90        | 37.32        | 3.58        |
| St-Ambroise Abr. | 28.25          | 29.97          | 8.04          | 3.29          | 1.72         | 5.74        | 5.74       | 1.72          | 0.55         | 40.90        | 38.55        | 2.35        |
| Belle.G Rousse   | 178.25         | 176.49         | 48.05         | 15.12         | -1.76        | -1.00       | -1.00      | 0.00          | 0.00         | 31.48        | 31.79        | -0.31       |
| <b>Total</b>     | <b>2403.50</b> | <b>2459.36</b> | <b>687.80</b> | <b>253.77</b> | <b>55.86</b> | <b>1.36</b> | <b>N/A</b> | <b>118.51</b> | <b>43.55</b> | <b>39.12</b> | <b>37.27</b> | <b>1.85</b> |